



# JEEP WRANGLER STEERING BOX SKID PLATE INSTRUCTION SHEET

K6858941

## PLEASE READ ALL INSTRUCTIONS COMPLETELY BEFORE INSTALLING ROCKER GUARD

### COMPONENTS

<u>ITEM</u>	<u>QTY</u>	<u>DESCRIPTION</u>
1	1	Steering Box Skid Plate
2	1	Steering Box Connector Bracket (For Mopar Tubular Bumper Only)

### HARDWARE

<u>ITEM</u>	<u>QTY</u>	<u>DESCRIPTION</u>
A	1	1/4"x3/4" Thread Rolling Torx Screw
B	1	1/4"x1" Self Drilling Hex Head Screw
C	1	1/4" Flange Nut S.S.

*Bag Contents – Items:2,A,B,C*

### MOPAR PART NUMBERS

82204732 Steering Box Skid Plate - Black

## INSTRUCTIONS: (For Vehicles Equipped with Mopar Tubular Bumpers)

1. Remove the 1/2" Bumper Bolt under the frame rail on the driver side which attaches the bumper to the frame rail and retain for step 7.
2. Remove the two frame rail bolts which attach the steering box to the frame and retain for step 3.
3. Position the **Steering Box Skid Plate** (Item 1) onto the vehicle and loosely attach by feeding the two frame rail bolts removed in step 2 through the **Skid Plate**.
4. Position the **Steering Box Connector Bracket** (Item 2) onto the **Steering Box Skid Plate** and scribe hole location where the **Connector Bracket** mates with the **Tubular Frame Support**. (See Figure 1.)
5. Attach **Steering Box Connector Bracket** to the **Tubular Frame Support** with the 1/4"x1" Self Drilling Hex Head Screw (Item B). \*Torque to 11 Ft-Lbs.
6. Reattach **Steering Box Skid Plate** as in step 3. \*Torque Steering Box Bolts to 70 Ft-Lbs.
7. Fasten the front of the **Steering Box Skid Plate** to the bumper with the 1/2" Bumper Bolt removed in step 1. \*Torque to 76 Ft-Lbs.
8. Fasten **Steering Box Connector Bracket** to the **Steering Box Skid Plate** with a 1/4"x3/4" Thread Rolling Torx Screw (Item A) and a 1/4" Flange Nut (Item C). \*Torque to 7 Ft-Lbs.

## INSTRUCTIONS: (For Vehicles Equipped with OEM Bumpers)

1. Remove the 1/2" Bumper Bolt under the front bumper on the driver side which attaches the bumper to the frame rail and retain for step 7.

2. Remove the two frame rail bolts which attach the steering box to the frame and retain for step 3.
3. Position the **Steering Box Skid Plate** (Item 1) onto the vehicle and loosely attach by feeding the two frame rail bolts removed in step 2 through the **Skid Plate**.
4. Scribe the hole location onto the bumper from the small hole in the **Steering Box Skid Plate**.
5. Remove **Steering Box Skid Plate** and center punch scribed hole location. Drill with 7/32" drill bit.
6. Reattach **Steering Box Skid Plate** as in step 3. \*Torque Steering Box Bolts to 70 Ft-Lbs.
7. Fasten the front of the **Steering Box Skid Plate** to the bumper with the 1/2" Bumper Bolt removed in step 1. \*Torque to 76 Ft-Lbs.
8. Screw the **Thread Rolling Torx Screw** (Item A) through the **Steering Box Skid Plate** (Item A) and into the drilled hole in the bumper. \*Torque to 7 Ft-Lbs

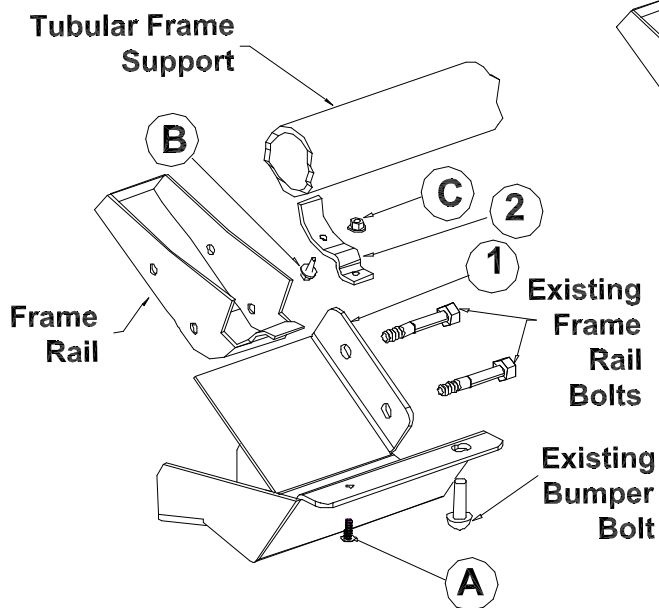

For Vehicles NOT Equipped With OEM Bumper

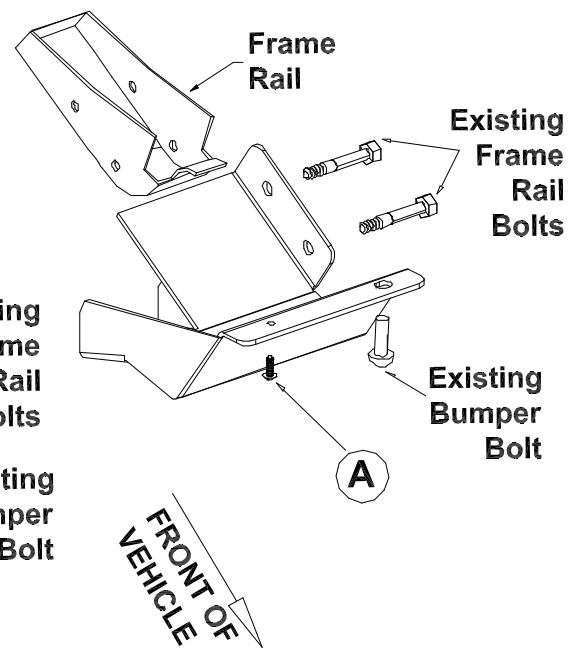

For Vehicles Equipped With OEM Bumper

**FOR INSTALLATION ASSISTANCE CALL 1-800-739-6837**