

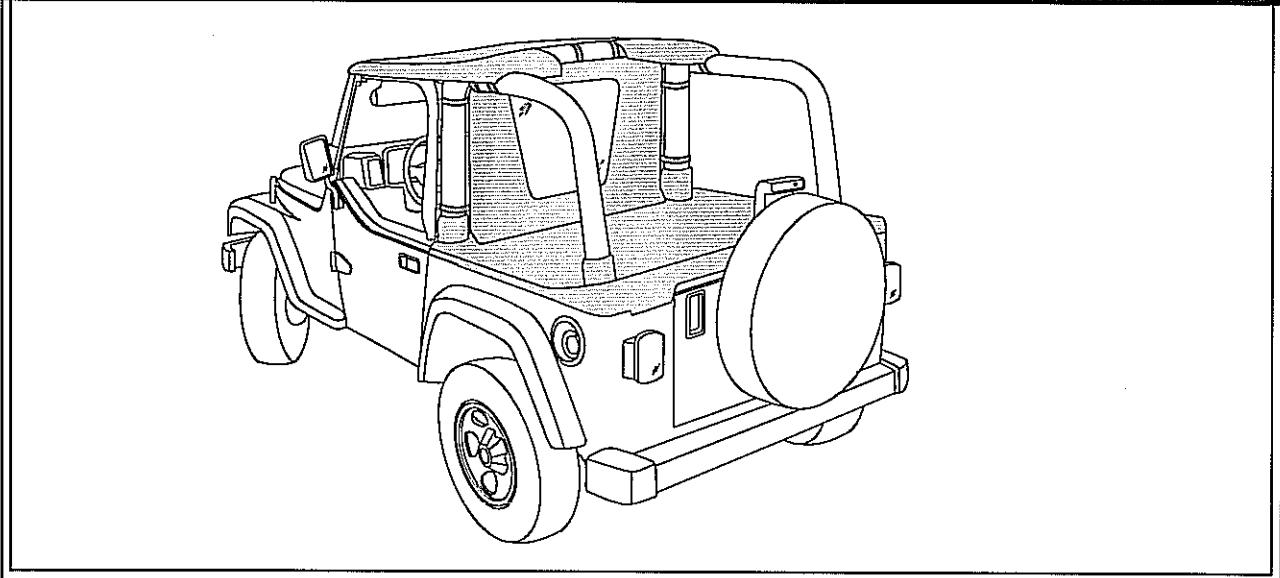

GENUINE ACCESSORIES



GB **INSTALLATION INSTRUCTION** **SUNBONNET COMBO**
Parts must not be fitted until registration of the vehicle has been obtained.

E **INSTRUCCIONES DE MONTAJE**
No se permite montar las piezas antes de registrar el vehículo.

F **NOTICE DE MONTAGE**
Ne pas monter les pièces avant l'enregistrement du véhicule.

JP

Subject to alteration without notice
Reservadas modificaciones técnicas
Sous réserve de modifications techniques

This SUNBONNET COMBO is for use on Soft Top Vehicles. It may be used on Hard Top Vehicles with purchase of Hardward Kit 82209936.

82209926
82209935

© DAIMLERCHRYSLER

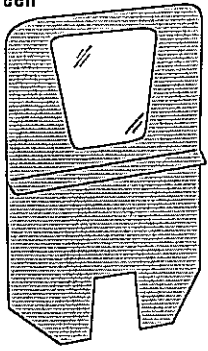
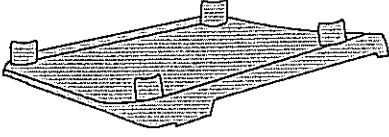
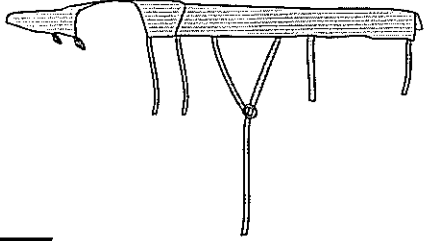
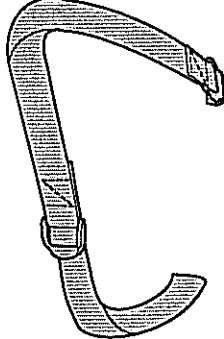
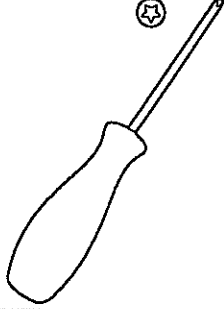
GENUINE ACCESSORIES		
<p>Windscreen</p>  <p>A</p>	<p>Tonneau</p>  <p>B</p>	<p>Sunbonnet</p>  <p>C</p>
<p>Seat Strap</p>  <p>D</p>		
<p>T30 Torx Driver</p>  <p>1</p>		

GENUINE ACCESSORIES

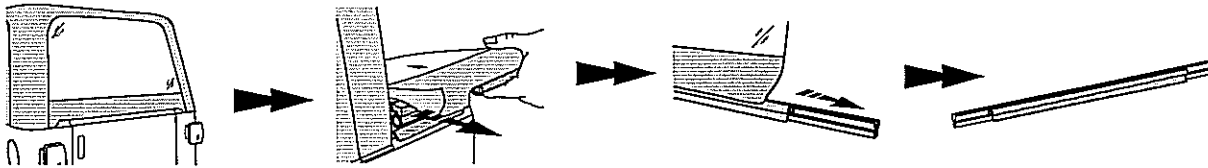

1

Open zipper on Rear Window. Pull the Tailgate Retainer Bar out of the mounts on the vehicle.

Slide the Tailgate Retainer Bar off the Rear Window and set it aside to be used later.

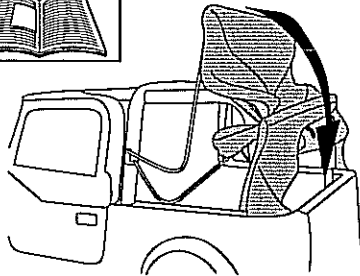

2

Release the front of the top from the windshield and lay the bows down. Refer to owner's manual for instructions.

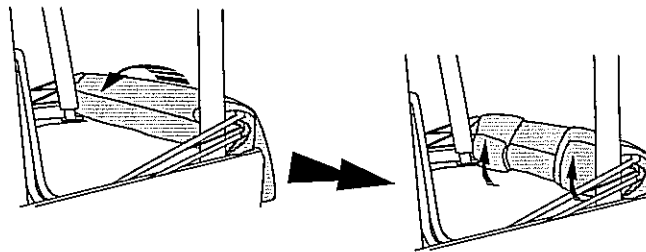

3

Wrap the top fabric tightly around the bows. Then wrap the legs tightly around the top fabric.

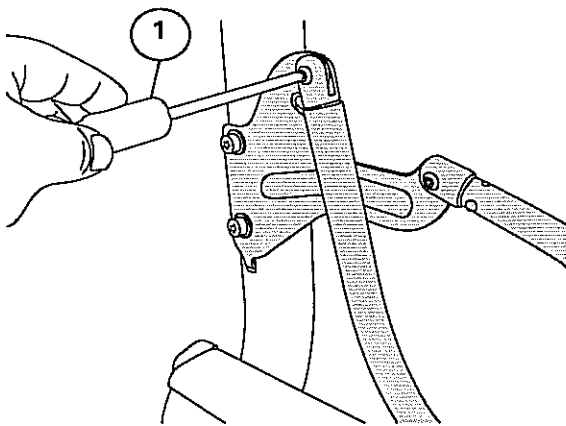

4

Use a T30 Torx to remove the soft top assembly.

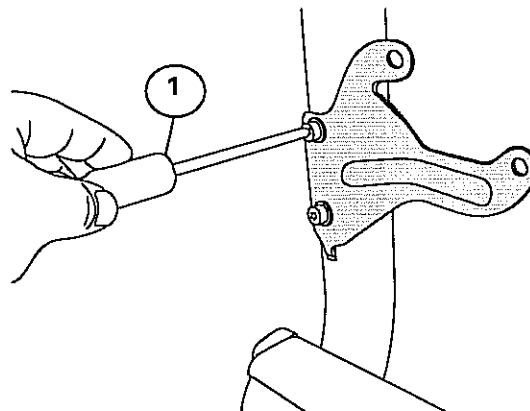

5

Use a T30 Torx to remove the main Pivot Brackets.



Mopar

PARTS

GENUINE ACCESSORIES



For ease in installation, the Sunbonnet Combo should be installed at temperatures above 72° F. Below this temperature, the fabric may contract an inch or more, making it difficult to fit to the vehicle.

It is normal for the fabric to contract and wrinkle when stored in the shipping carton. Within a few days after the installation, the fabric will relax and the wrinkles will disappear.

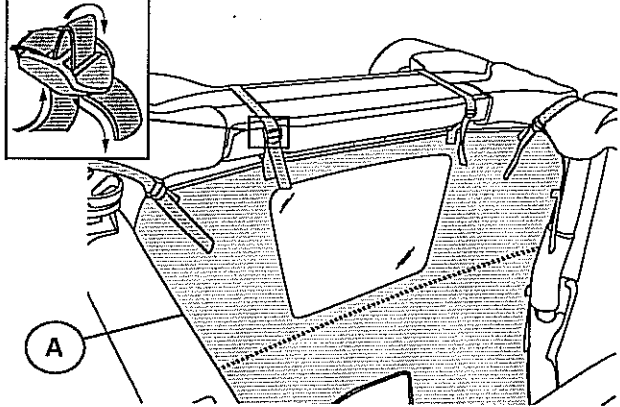

6A Orient the Windjammer with the window toward the top and with the vinyl side out. Start with the top straps and thread the end of each strap around the sport bar and through each buckle. Loosely tighten each strap to hold the Windjammer in position.

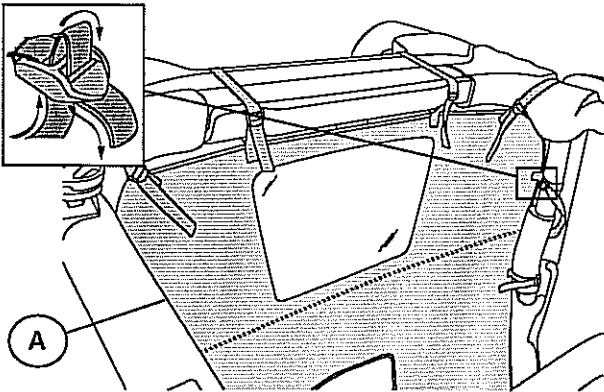

6B Thread the side straps loosely around the side sport bars.

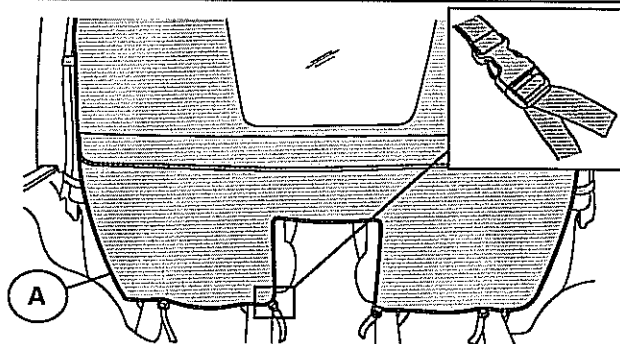

Pull down gently on the fabric and thread the straps through the back of the seat brackets. Buckle the straps.

7 Tighten all straps.

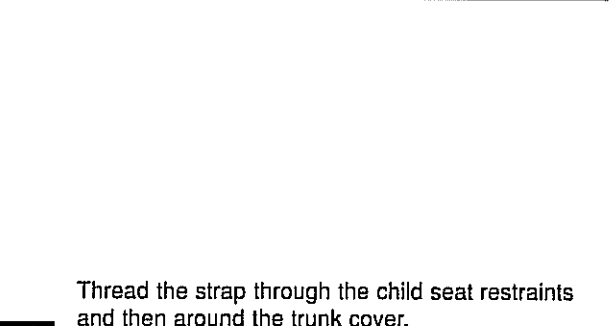

Thread the strap through the child seat restraints and then around the trunk cover.

8 Tighten the strap and pull the seat forward.

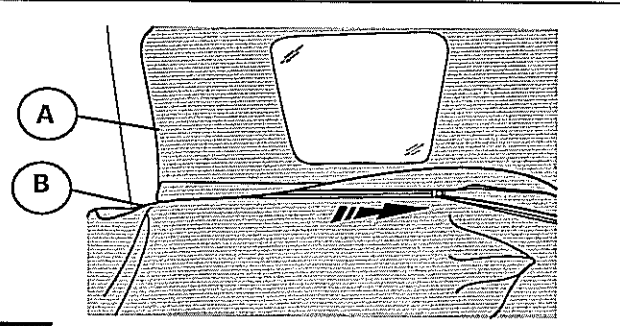

9 Zip the Tonneau to the Windscreen.

GENUINE ACCESSORIES

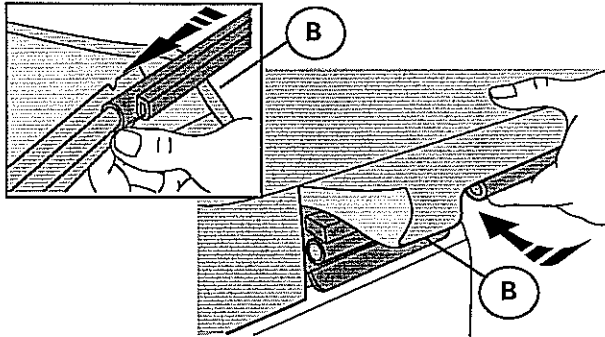

10

Slide the "C" channel on the Tailgate Retainer onto the tubed strip sewn to the rear of the Tonneau. Insert the Tailgate Bar into the mounts on each side of the tailgate opening.

X2

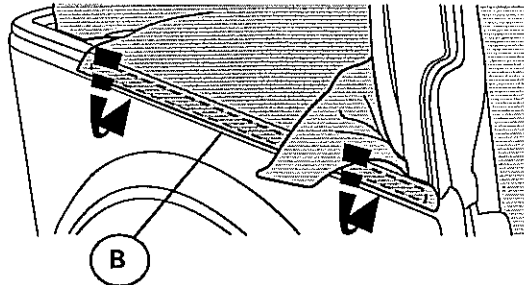

11

Roll the plastic strip on each side of the Tonneau into the retainer channel on the vehicle.

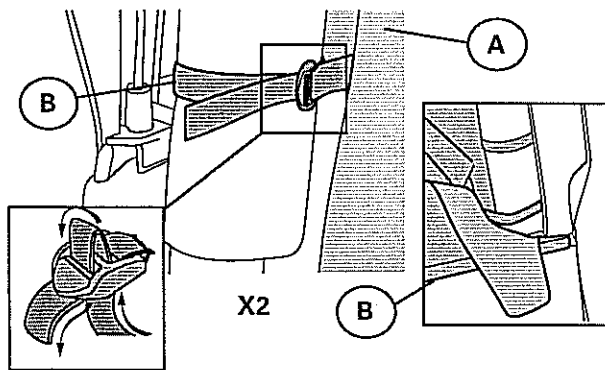

12

Wrap the straps on the front of the Tonneau around the sport bar and the bows. Thread the end through the buckle.

X2

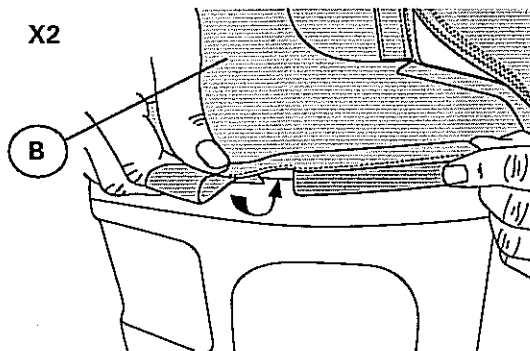

13

Roll the plastic strip on the rear corners of the Tonneau into the retainer channel on the vehicle.

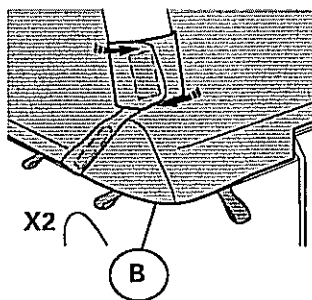

14

Wrap the two (2) collars around the rear sport bars and fasten the hook and loop strips to each other.

X2

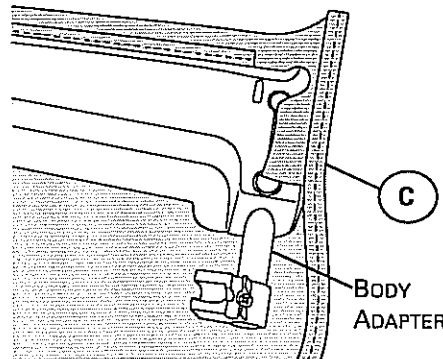

15

Orient the Sunbonnet with the body adapter toward the front.

GENUINE ACCESSORIES

X2

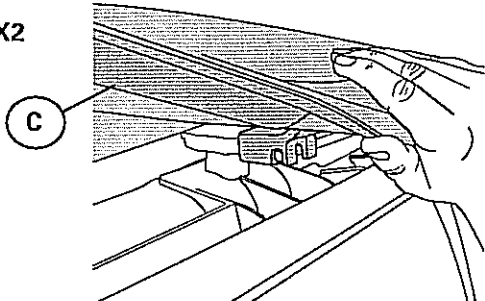

Place the Sunbonnet on the vehicle. Hook the body adapter on each side over the ledge of the door surround.

16

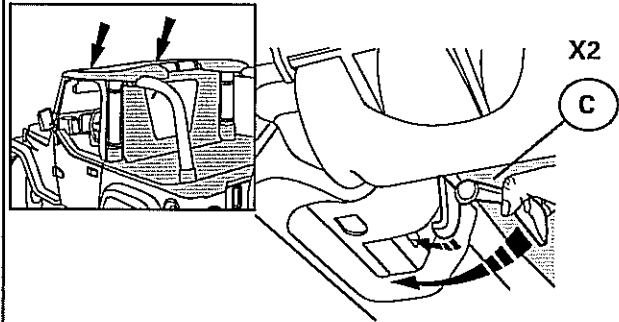

Latch the front of the Sunbonnet to the windshield.

17

X2

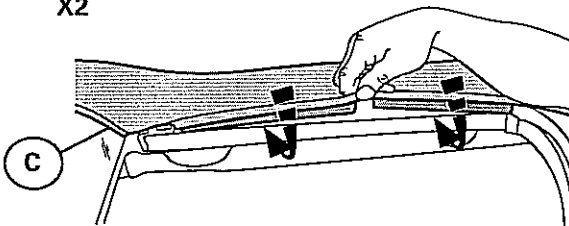

Roll the plastic strip above each door opening into the channel above the door on each side of the vehicle.

18

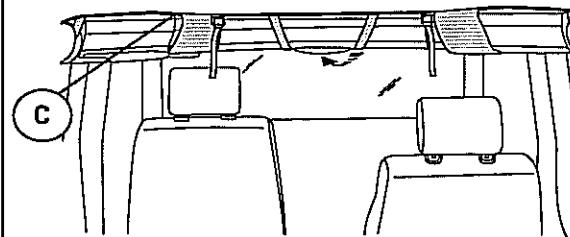

Pull the long strap around the sport bar, between the sport bar and the Windjammer and toward the front of the vehicle.

19

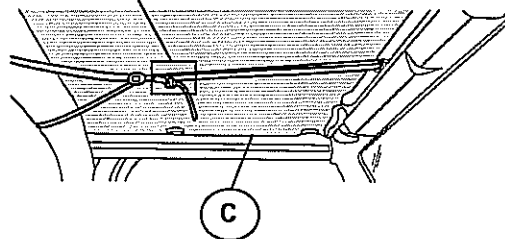

Thread the strap through the footman loop above the windshield. Pull the end of the strap back and thread it through the buckle. Pull it tight.

20

X2

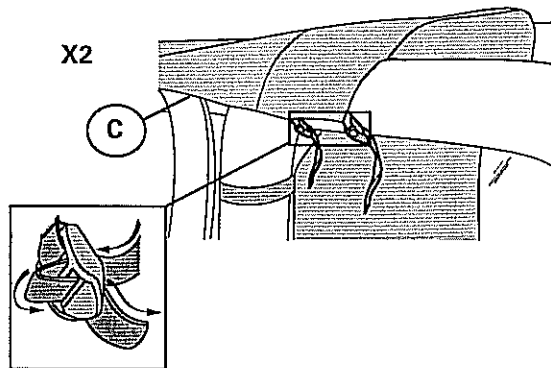

Wrap the straps on the rear of the Sunbonnet around the speaker pods, two straps on each side. Thread them through the buckles.

21

Tighten all straps.



ACCESSOIRES D'ORIGINE

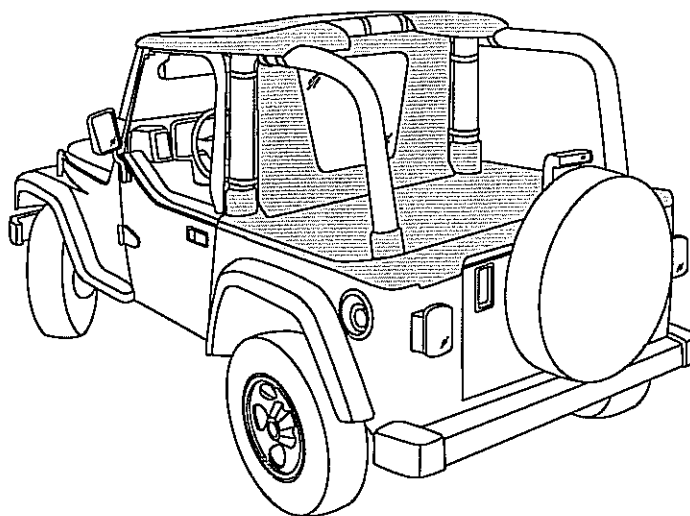

GB

INSTALLATION INSTRUCTION

Parts must not be fitted until registration of the vehicle has been obtained.

SUNBONNET COMBO

E

INSTRUCCIONES DE MONTAJE

No se permite montar las piezas antes de registrar el vehículo.

F

NOTICE DE MONTAGE

Ne pas monter les pièces avant l'enregistrement du véhicule.

COMBO CAPOT PARE-SOLEIL



JP

Subject to alteration without notice
Sujeto a modificación sin previo aviso
Sous réserve de modifications techniques

Ce COMBOT CAPOT
PARE-SOLEIL doit être utilisé
sur les véhicules décapotables.
Il peut être utilisé sur les
véhicules à toit amovible avec
l'achat de la trousse Hardward
82209936.

82209926
82209935

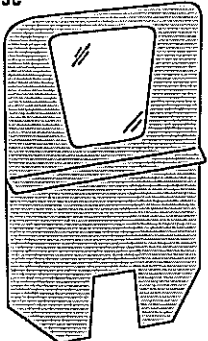
© DAIMLERCHRYSLER

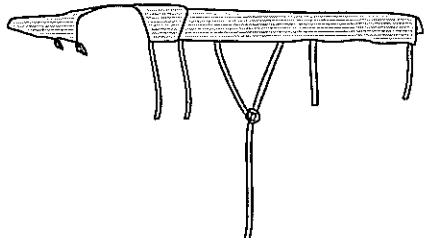
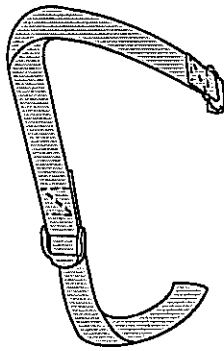
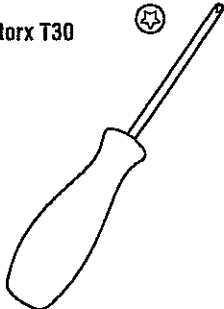
ACCESSOIRES d'ORIGINE		
<p>Pare-brise</p>  <p>A</p>	<p>Couvre-bagages</p>  <p>B</p>	<p>Capot pare-soleil</p>  <p>C</p>
<p>Ceinture de sécurité</p>  <p>D</p>		
<p>Tournevis torx T30</p>  <p>1</p>		

ACCESSOIRES d'ORIGINE

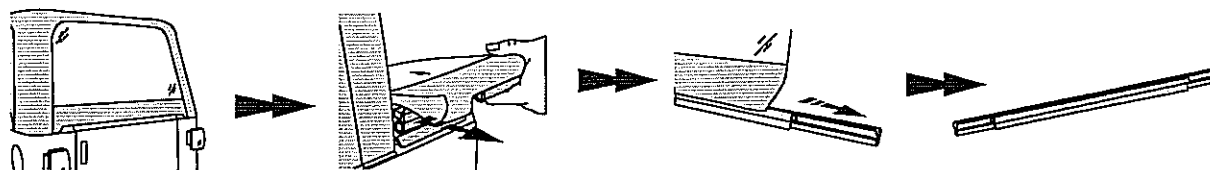

1

Ouvrir la fermeture à glissière de la lunette arrière. Tirer la barre de retenue du hayon hors des montants du véhicule.

Faire glisser la barre de retenue du hayon hors de la lunette arrière et la mettre de côté pour l'utiliser plus tard.

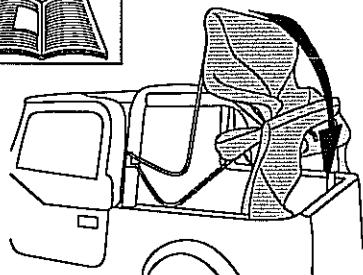

2

Démonter l'avant du toit du pare-brise et coucher les arceaux. Pour le mode d'emploi, vous référer au manuel de l'utilisateur.

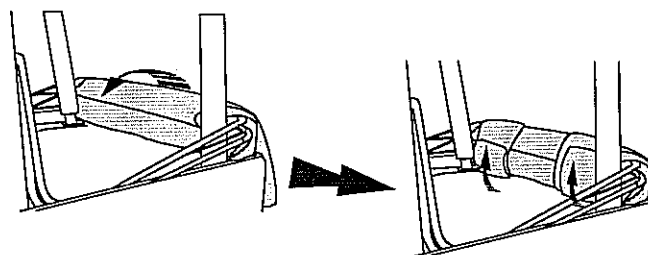

3

Enrouler étroitement la toile de toit autour des arceaux. Ensuite enrouler étroitement les pattes autour de la toile de toit.

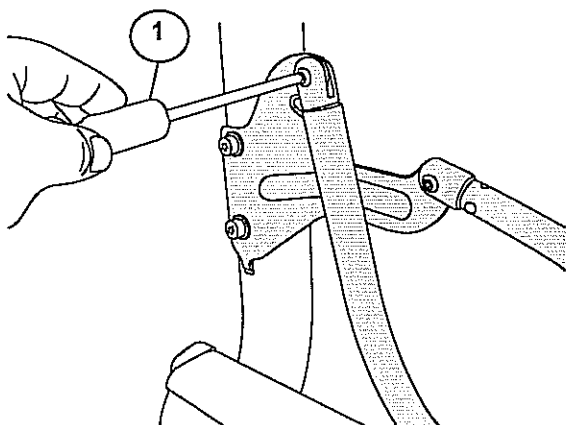

4

Utiliser un tournevis torx T30 pour retirer l'assemblage du toit amovible.

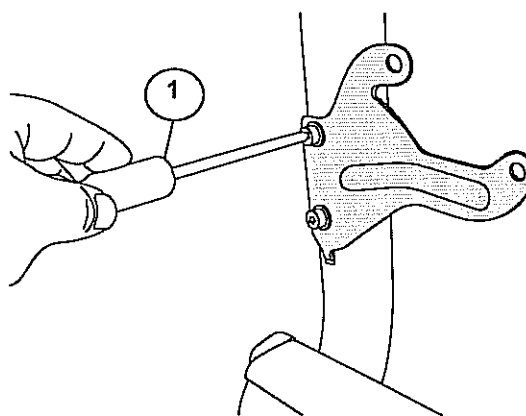

5

Utiliser un tournevis torx T30 pour retirer les principaux supports pivotants.

ACCESSOIRES D'ORIGINE



Pour faciliter l'installation, le Combo capot pare-soleil doit être installé à des températures supérieures à 72 °F. En dessous de cette température, la toile peut se contracter d'un pouce ou davantage, rendant l'ajustement au véhicule difficile.

Il est normal que la toile se contracte et se plisse lorsqu'elle est entreposée dans le carton d'expédition. Quelques jours après l'installation, la toile se détendra et les plis disparaîtront.

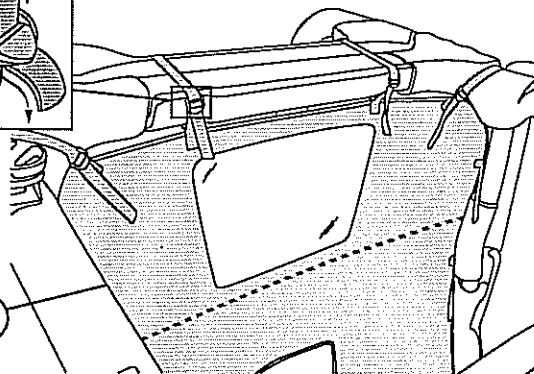

Orienter le carénage avec la fenêtre vers le toit et avec le côté du vinyle à l'extérieur. Débuter avec les sangles du toit et passer l'extrémité de chaque sangle autour des barres de sport et dans chaque boucle. Serrer chaque sangle de manière lâche pour maintenir le carénage en place.

6A

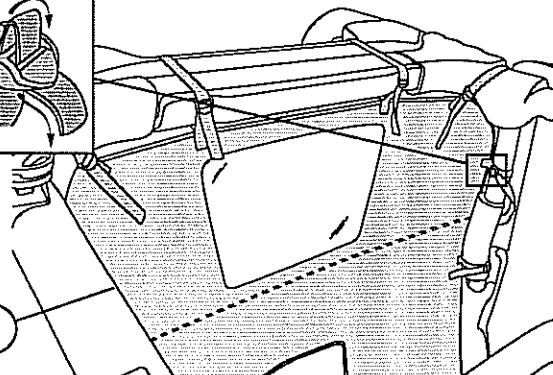

6B

Passer les sangles latérales de manière lâche autour des barres de sport latérales.

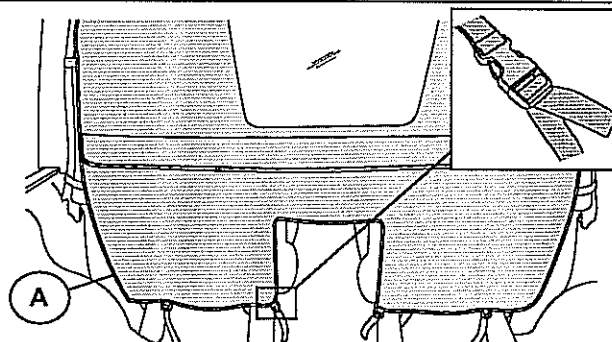

Abaisser délicatement la toile et passer les sangles à l'arrière des supports de siège. Boucler les sangles.

7

Serrer toutes les sangles.

8

Passer la sangle dans les brides du siège de sécurité pour enfant, puis autour du couvercle du coffre.

Serrer la sangle et tirer le siège vers l'avant.

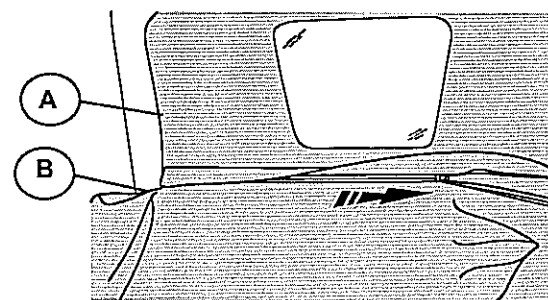

9

Attacher le couvre-bagages au pare-brise avec la fermeture à glissière.

ACCESSOIRES D'ORIGINE

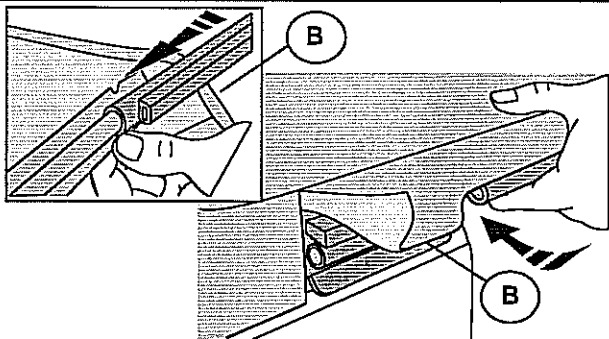

Faire glisser le montant "C" de la fixation du hayon sur la bande tubulaire cousue à l'arrière du couvre-bagages. Insérer la barre de hayon dans les montants sur chaque côté de l'ouverture du hayon.

10

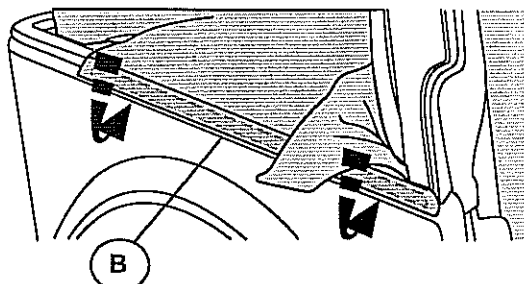

Rouler la bande de plastique sur chaque côté du couvre-bagages dans le montant de retenue sur le véhicule.

11

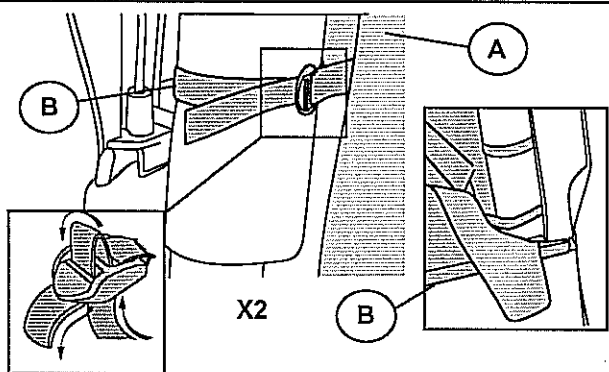

Enrouler les sangles sur le devant du couvre-bagages autour de la barre de sport et des arceaux. Passer l'extrémité dans la boucle.

12

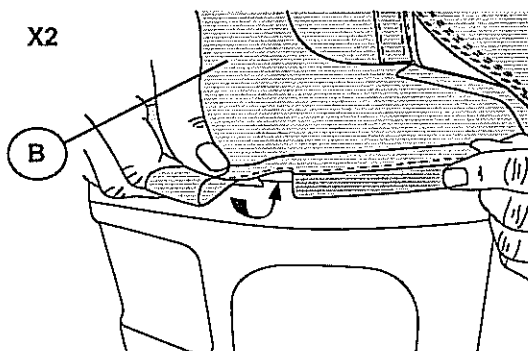

Rouler la bande de plastique sur les coins arrière du couvre-bagages dans le montant de retenue sur le véhicule.

13

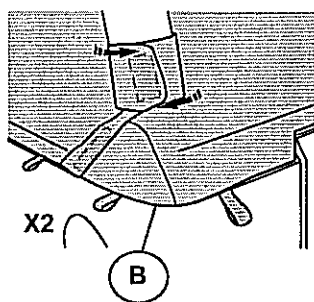

Enrouler les deux (2) rondelles autour des barres de sport arrière et fixer les bandes de Velcro l'une à l'autre.

14

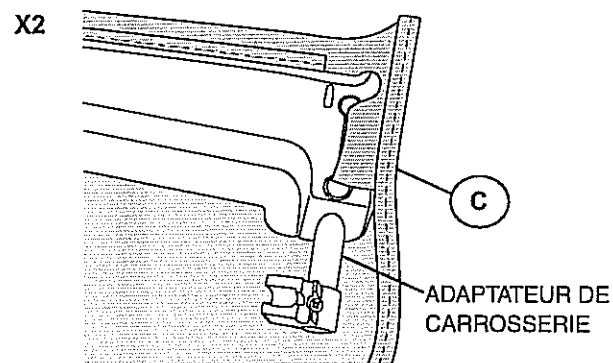

Orienter le capot pare-soleil avec l'adaptateur de carrosserie en direction du devant.

15

ACCESSOIRES D'ORIGINE

X2

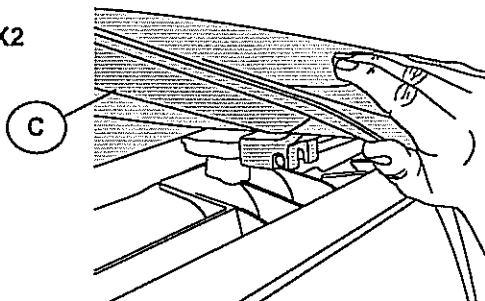

Placer le capot pare-soleil sur le véhicule. Accrocher l'adaptateur de carrosserie sur chaque côté par-dessus la traverse du cadre de portière.

16

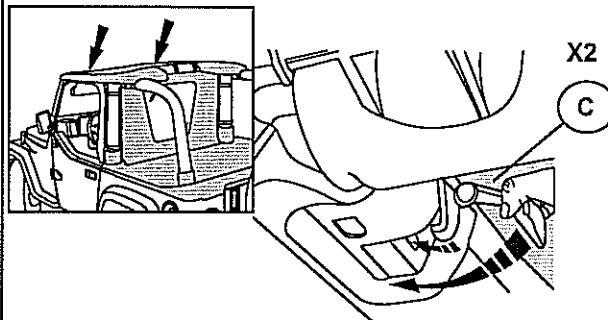

Verrouiller l'avant du capot pare-soleil au pare-brise.

17

X2

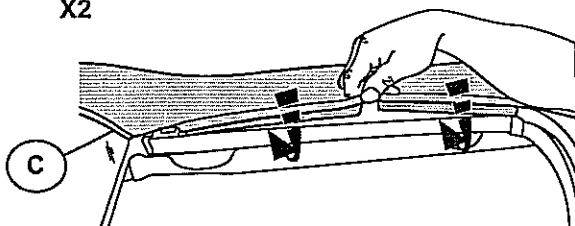

Rouler la bande de plastique au-dessus de chaque ouverture de portière dans le montant au-dessus de la portière de chaque côté du véhicule.

18

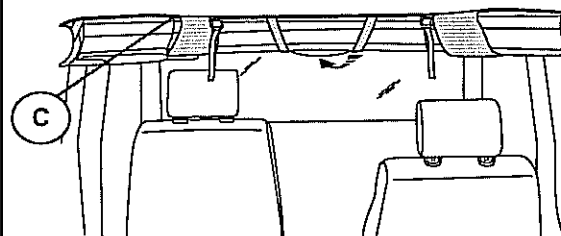

Tirer la longue sangle autour de la barre de sport, entre la barre de sport et le carénage et vers l'avant du véhicule.

19

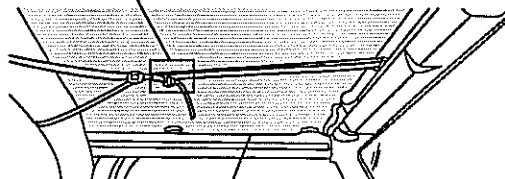

Passer la sangle dans la boucle de valet de pied au-dessus du pare-brise. Tirer l'extrémité de la sangle vers l'arrière et la passer dans la boucle. Serrer fermement.

20

X2

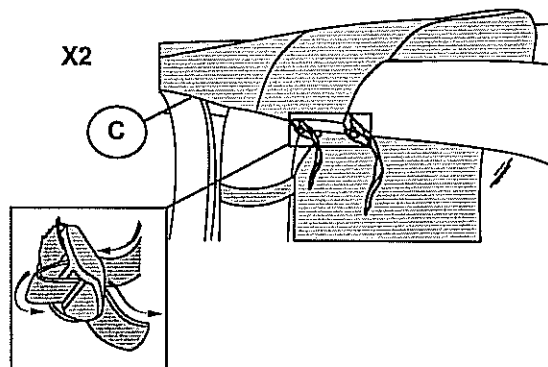

Enrouler les sangles sur l'arrière du capot pare-soleil autour des modules de haut-parleur, deux sangles de chaque côté. Passer les sangles dans les boucles. Serrer toutes les sangles.

21

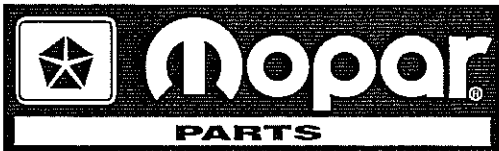

ACCESORIOS ORIGINALES

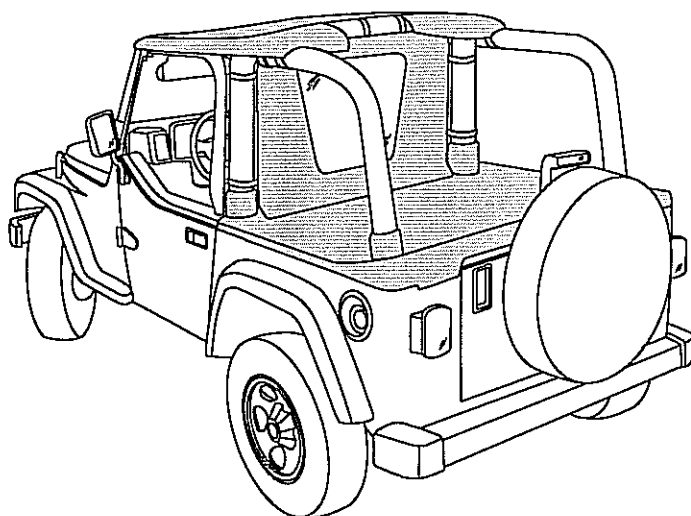

GB	INSTALLATION INSTRUCTION Parts must not be fitted until registration of the vehicle has been obtained.	SUNBONNET COMBO
E	INSTRUCCIONES DE MONTAJE No se permite montar las piezas antes de registrar el vehículo.	COMBO TECHO PARASOL
F	NOTICE DE MONTAGE Ne pas monter les pièces avant l'enregistrement du véhicule.	COMBO CAPOT PARE-SOLEIL
JP		



Subject to alteration without notice
 Sujeto a modificación sin previo aviso
 Sous réserve de modifications techniques

El presente COMBO TECHO PARASOL es sólo para vehículos con techo de lona. Puede usarse en vehículos con Techo Duro con la compra de un Juego de "Hardware" 82209936.

82209926
82209935

© DAIMLERCHRYSLER

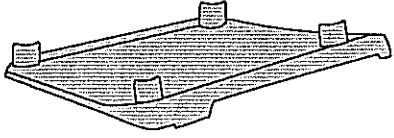
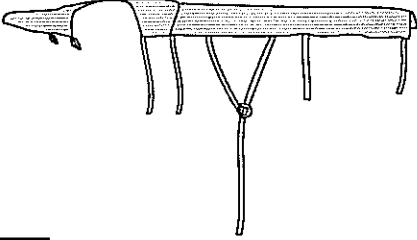
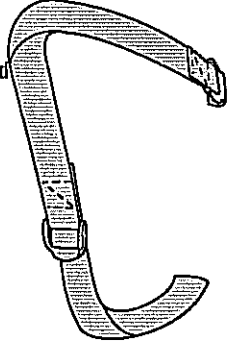
ACCESORIOS ORIGINALES

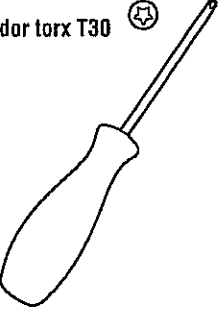
<p>Parebrisas</p>  <p>A</p>	<p>Cobertor de Portaequipaje</p>  <p>B</p>	<p>Techo Parasol</p>  <p>C</p>
<p>Cinturón de Seguridad</p>  <p>D</p>		
<p>Destornillador torx T30 </p>  <p>1</p>		

ACCESORIOS ORIGINALES

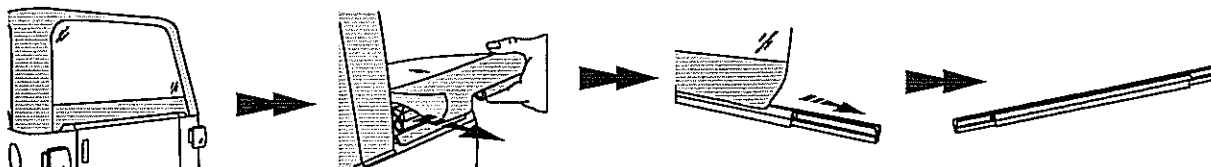

1

Abra la cremallera de la Ventana Trasera. Extraiga la Barra de Retención de la Compuerta Trasera del Bastidor del vehículo.

Deslice la Barra de Retención de la Compuerta Trasera y apártela para usarla luego.

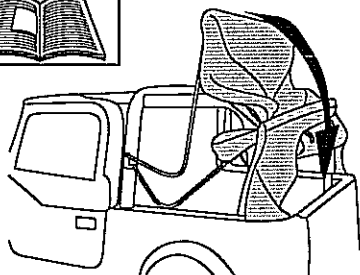

2

Libere el frontal del techo del parabrisa y pliegue la armazón hacia atrás. Remítase al Manual del Propietario para instrucciones.

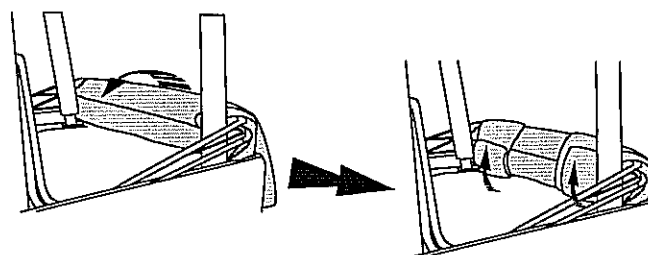

3

Recoja y enrolle de manera bien compacta la lona del techo alrededor del eje del armazón.

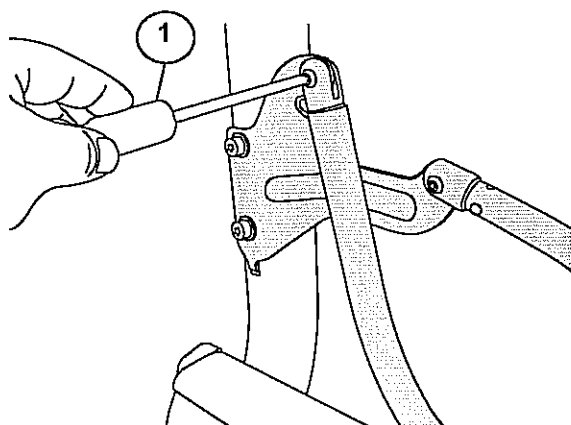

4

Utilice el destornillador T30 para retirar la estructura del techo de lona.

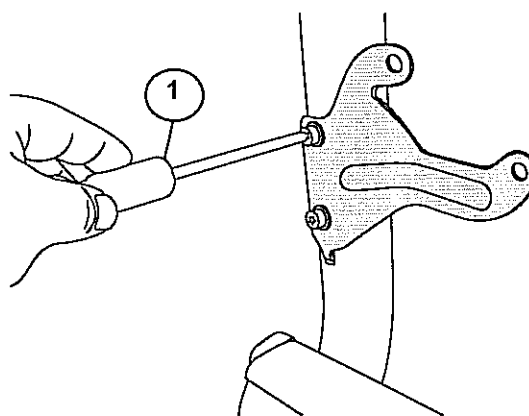

5

Utilice el destornillador T30 para retirar las Bisagras Basculantes principales.



Mopar

PARTS

ACCESORIOS ORIGINALES



A fin de facilitar su instalación, debe armar el Combo Techo Parasol a temperaturas mayores de 72 grados Fahrenheit. A temperaturas menores, la lona se contraerá una pulgada o más, dificultando su ajuste al vehículo.

Es normal que la lona se contraiga y arrugue debido al almacenaje en el empaque de cartón. Unos días luego de su instalación, la lona se extenderá y las arrugas desaparecerán.

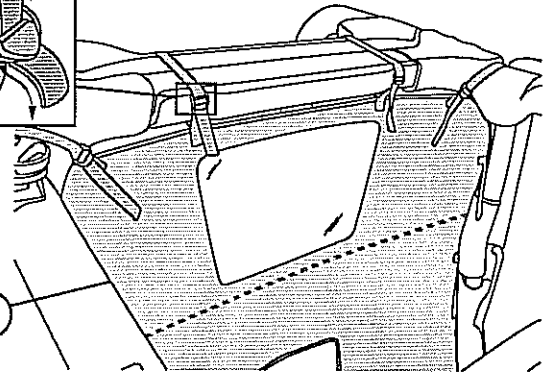
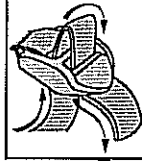

Oriento el deflector de viento "Windjammer" con la ventana hacia el techo y con la parte de vinilo hacia fuera. Comience con las correas del techo, enlace el extremo de las correas alrededor de la barra antivuelco y hágalos pasar a través de las hebillas. Tense ligeramente cada correa para colocar en posición correcta el deflector de viento Windjammer.

6A

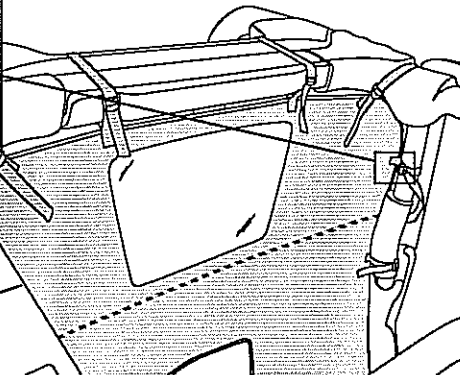

6B

Enlace las correas laterales suavemente alrededor de los laterales de la barra antivuelco.

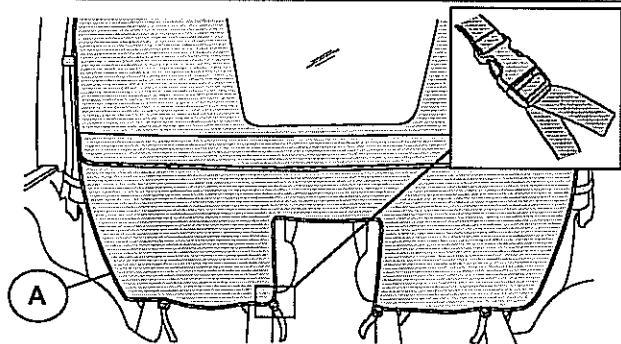

7

Jale la lona hacia abajo suavemente y enlace las correas a través de la parte trasera de las orejeras de los asientos.

Tense las correas.

Enlace las correas a través de los seguros de sillas para niños y luego alrededor del cobertor de la cajuela.

8

Tense las correas y jale el asiento hacia atrás.

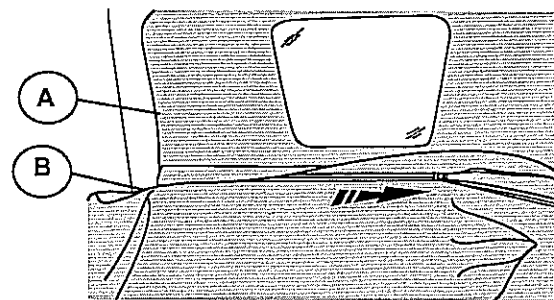

9

Cierre la cremallera que une al cobertor de la cajuela con la pantalla de viento.



Mopar

PARTS

ACCESORIOS ORIGINALES

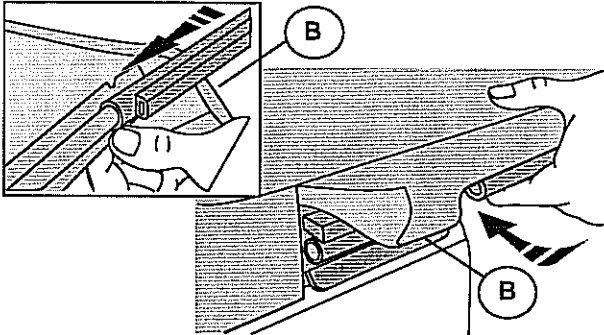

Deslice el canal "C" de Retén de la Compuerta Trasera del vehículo por dentro de la tira tubular zurcida a la parte trasera del Cobertor de la Cajuela. Inserte la Barra de Retención en los bastidores a cada lado de las aberturas de la compuerta trasera.

10

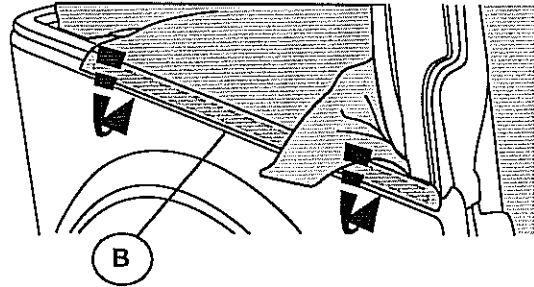

Enrolle la tira plástica a cada lado del Cobertor de la Cajuela adentro del canal de retención del vehículo.

11

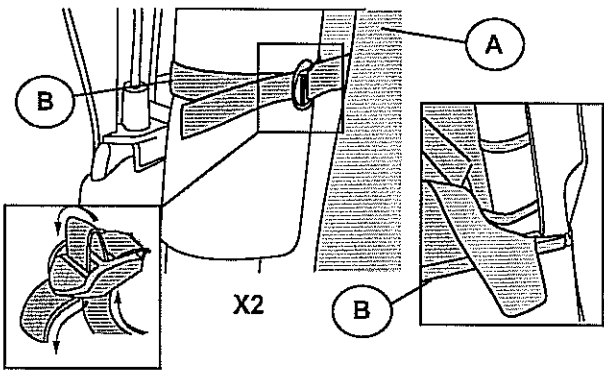

Enrolle las correas en la parte delantera del Cobertor de la Cajuela alrededor de la barra antivuelco y el armazón. Enlace el extremo a través de la hebilla.

12

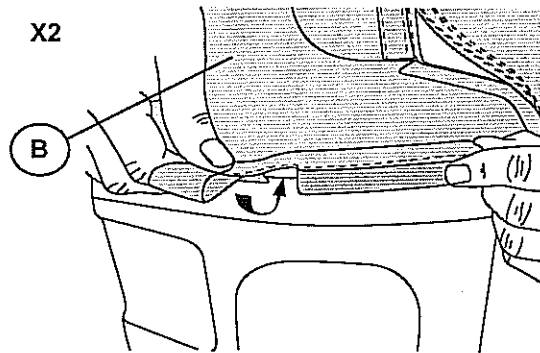

Enrolle la tira plástica en las esquinas traseras del Cobertor de la Cajuela por dentro del canal de retención del vehículo.

13

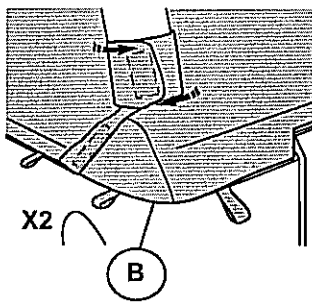

Enrolle las dos mangas alrededor de la parte trasera de la barra antivuelco y asegure los ganchos a las abrazaderas de tela.

14

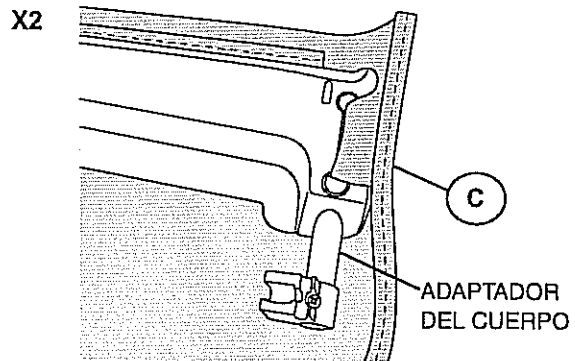

Posicione el Techo Parasol con el Adaptador del Cuerpo hacia delante.

15

ACCESORIOS ORIGINALES

X2

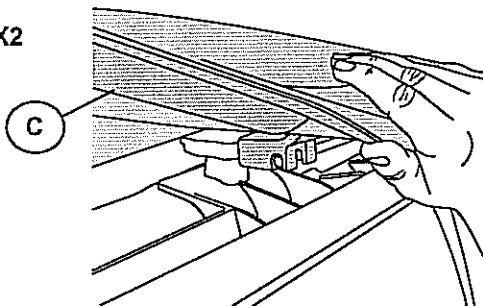

Coloque el Techo Parasol sobre el vehículo.
Enganche el Adaptador del Cuerpo a cada lado sobre el reborde que circunda a la puerta.

16

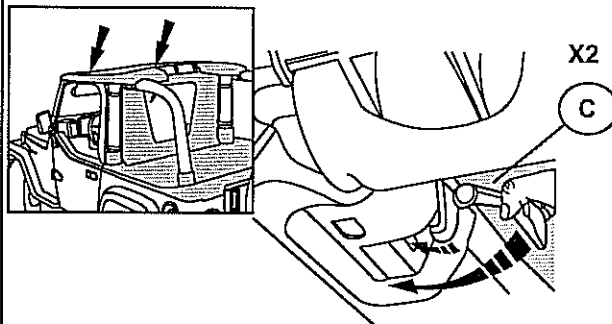

Enganche el frontal del Techo Parasol al parabrisas.

17

X2

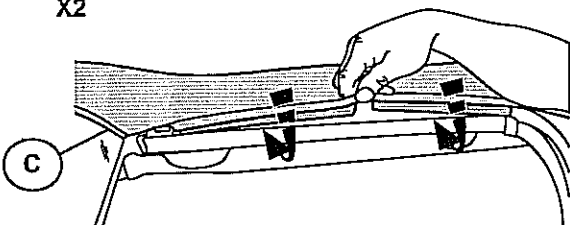

Enrolle la tira plástica por sobre la abertura de cada puerta, dentro del canal encima de la puerta a cada lado del vehículo.

18

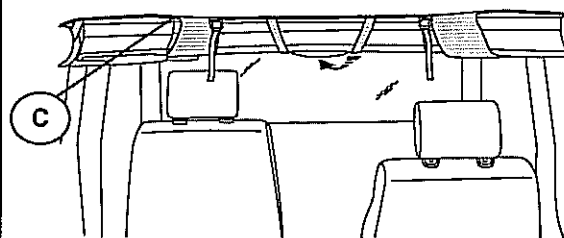

Jale la corre larga alrededor de la barra antivuelco, entre la barra antivuelco y el deflector de viento "Windjammer" y hacia la parte frontal del vehículo.

19

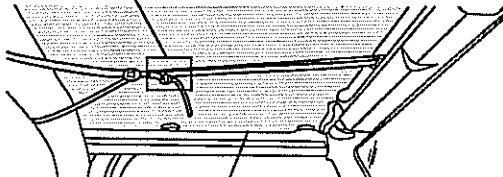
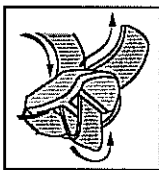

Enlace la correa a través de la abrazadera que está sobre el parabrisas. Jale el extremo de la correa hacia atrás y hágalo pasar por la hebilla. Jale y tense firmemente.

20

X2

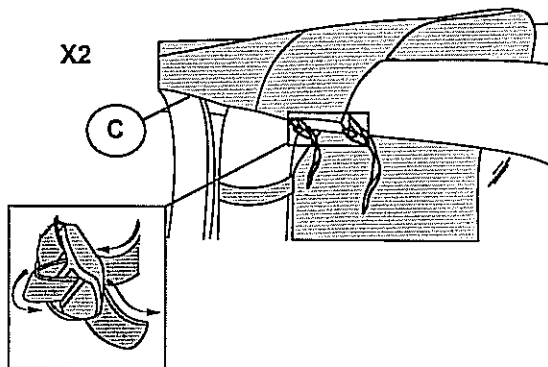

Enrolle las correas por la parte de atrás del Techo Parasol y alrededor de las barras de los parlantes de sonido, hay dos correas por lado; enlácelas a través de las hebillas.

21

Tense las correas firmemente.